

Introduction, 6 cylinder engines

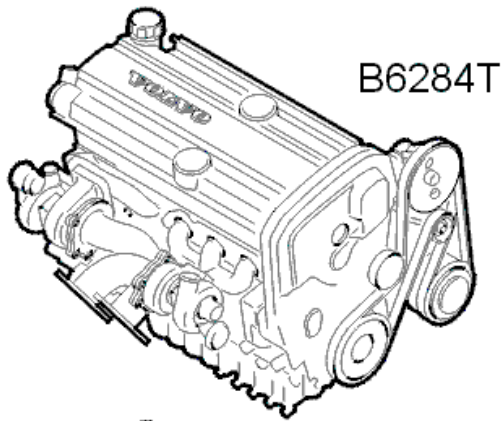

B6284T

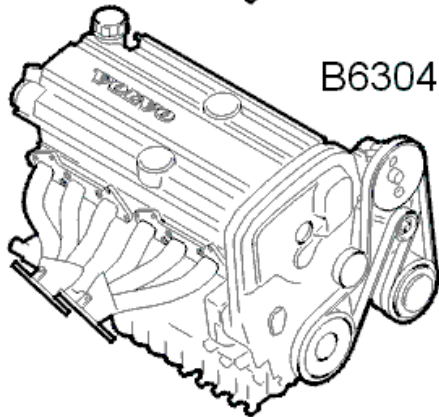

B6304S

P2X

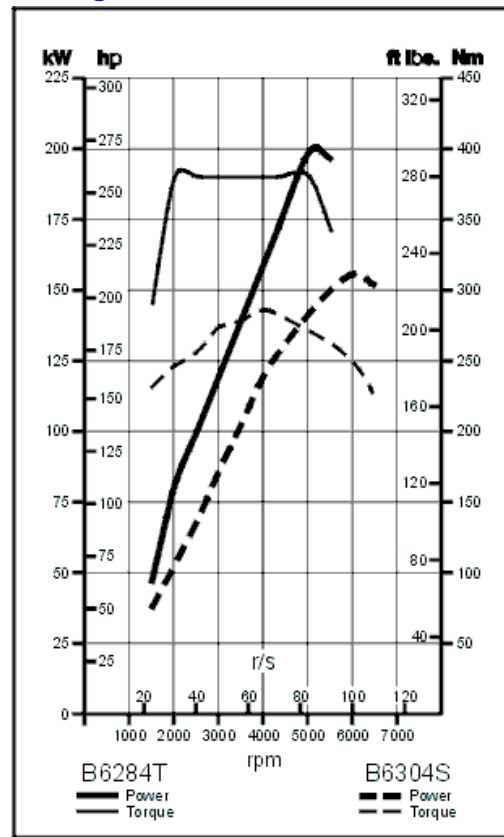

2000218e VOLVO

General

A large number of components are new compared to the engines in the S/V70 and S/V90. 6-cylinder engine \Rightarrow approximately 90% of the main components are new. The modifications result in reduced fuel consumption, increased performance and approximately a 7-8% reduction in CO₂ emissions.

The S80 fulfills the requirement for emissions according to TLEV.

The six cylinder engines have double catalytic converters, each catalytic converter consists of a monolith insert and a ceramic insert.

The front heated oxygen sensors (HO2S) are of the linear type. The linear heated oxygen sensors (HO2S) means that the emissions can be controlled more accurately at cold starts and under high loads.

Engine management system, ME 7.0

Engine variant	Power output kW (bhp)	Max torque Nm (lb.ft.)	0 - 100 Km/h (0 - 62 mph)
B6284T (Automatic transmission 4T65 EV-GT)	200 (272 bhp) at 5400 rpm	380 / 2000-5000 rpm	6.6 seconds

B6304S (Automatic transmission 4T65 EV/ Manual transmission, M65)	150 (204 bhp) at 6000 rpm	280 / 2000- 5400 rpm	7.8 seconds
---	------------------------------	-------------------------	-------------